

NAME: LED Corn Light

P/N: NLS-CL-60W

Advantage

- CE RoHS certificate
- E26/E27/E39/E40 lamp base
- Warm / Natural / Cool / Cold white
- 360degree lighting, high CRI
- Big heat sink
- Internal driver, input voltage AC85-300V or DC12-24V
- No UV or IR in the beam
- Easy to install and operate
- Energy saving, long service life
- Light is soft and uniform, safe to eyes
- Instant start, NO flickering, NO humming
- Green and eco-friendly without mercury



Application

Widely used in supermarket, warehouse, garage, home, office, hotel, hospital, school, street, garden etc.

NEWLITE SOLUTIONS LTD

Tel: 01132453089
www.newlitesolutions.co.uk

Fax: 01132453089
E-mail:sales@newlitesolutions.co.uk

PRODUCT SPECIFICATIONS				
Product name	LED Corn Light			
Part No	NLS-CL-60W			
Light Type	Corn Light			
Dimension	Φ 93*215mm			
Technical Characteristic				
Color	Warm white	Natural white	Cool white	Cold white
Color temperature	2700-3000K	4000-4250K	6000-6500K	7000-8000K
CRI	> 70	> 70	> 70	> 70
Lumen	6258.0	6498.0	6744.0	6624.0
Lumen Efficacy	104.3	108.3	112.4	110.4
Input Power	60 W			
Viewing Angle	360 degree			
Input Voltage	AC85-300V or DC12-24V 50/60Hz			
PFC	>90%			
Equivalent	400W incandescent / 120W CFL			
Waterproof Rating	IP20			
MATERIALS				
LED Brand	EPISTAR			
LED Type	SMD2835			
LED QTY	324 PCS			
Housing	PC			
Housing color	White			
OTHERS				
Operating Temperature	-20°C TO 45°C			
Operating Humidity	20%-70% RH			
Storage Temperature	-30°C TO 80°C			
Storage Humidity	10%-75% RH			
Application	Indoor			
Environment Protection	RoHS			
Safety Certification	CE			
Warranty Time	3 Years			

Measured Data of Lamp			
Voltage: 230.7 V	Current: 0.247 A	Power: 56.1 W	Power Factor: 0.983
Total Flux	5567.50 lm	Central Intensity	963.77 cd
Lamp Efficiency	0.00%	Light Efficiency	99.24 lm/W
Peak Intensity	1781.78 cd	Location of Peak(c, γ)	(310.0°, 27.9°)
Half-Intensity Angle	123.3°	Beam Angle	172.8°
Upward Light Ratio	0	Downward Light Ratio	100%
Upward Street Side	0	Downward Street Side	2611.73 lm
Upward House Side	0	Downward House Side	2955.66 lm
Flash Area(76°)	0 cm ²	Discomfort Glare(SLI)	0

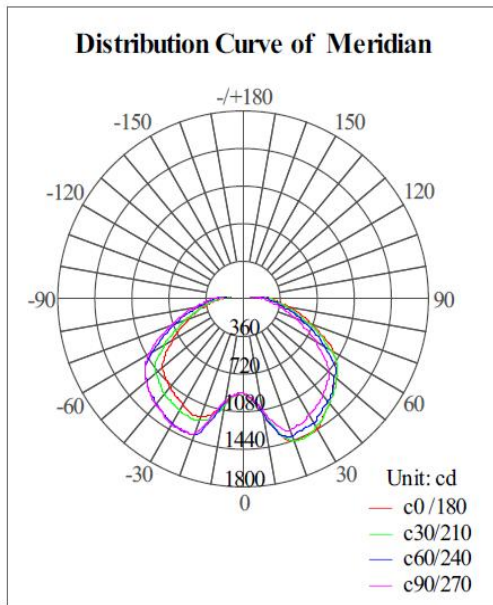

Illumination Cone Curve

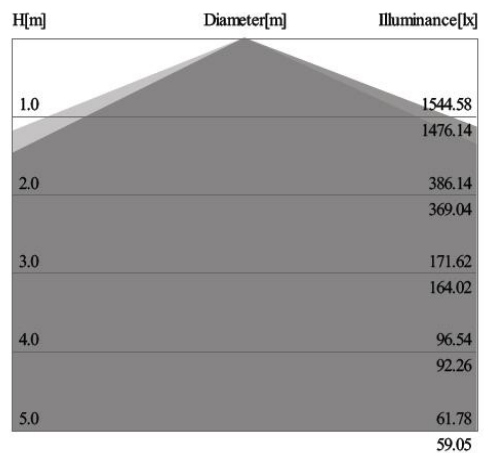

■ C0-C180
■ C90-C270

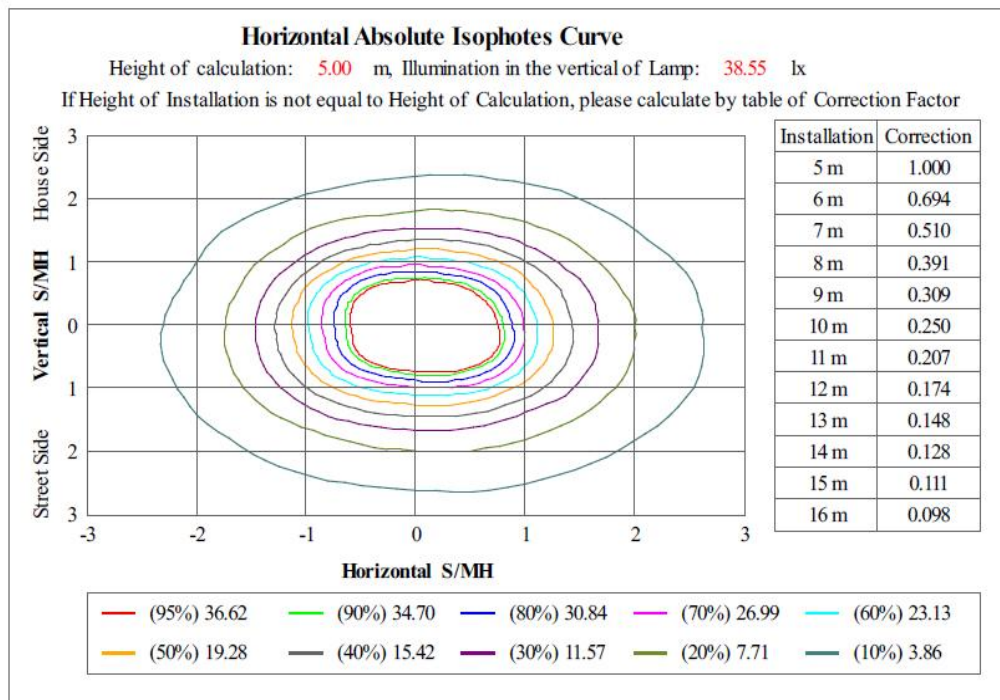

Package

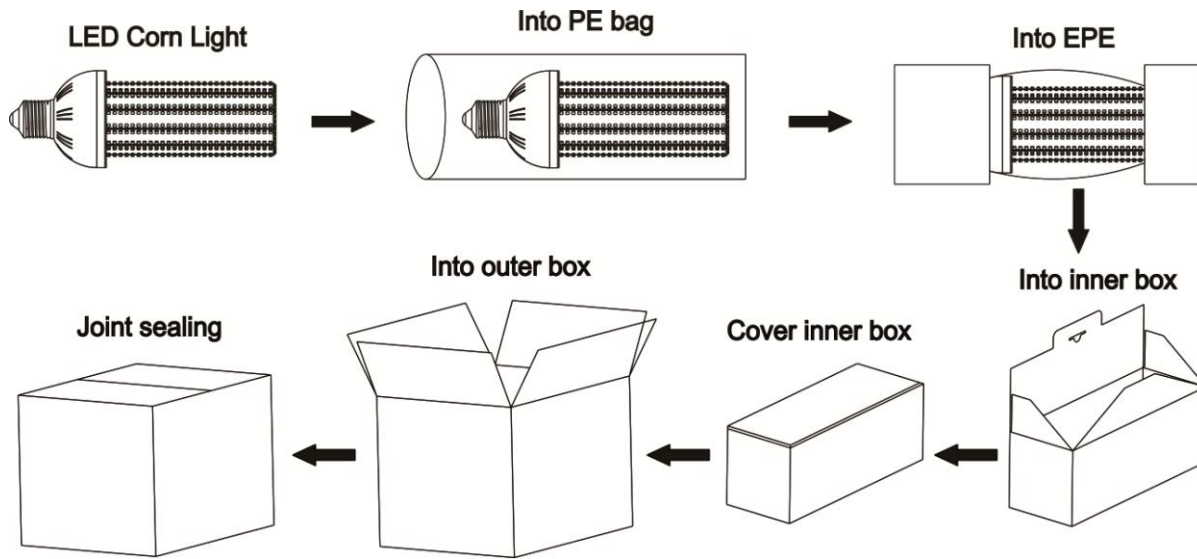

	Size	Qty/ Carton	Net Weight/ Carton	Gross Weight/ Carton
inner box	325*115*115mm	1	0.4kg	0.57kg
outer box	610*340*250mm	10	4kg	6kg

Notice For User

- Please turn off power before install or change assembly parts.
- The input voltage and lamps should be matched, after connecting the power line, please make sure the wiring section is insulated.
- Make sure to remove or bypass the electronic ballast in the fixtures before install the lamps.
- 15W/20W with internal driver are suitable for closed fixtures, 30W/40W/60W/80W/100W/120W, please don't use the lamps in closed fixtures, for closed fixtures, we suggest using external drive for the lamps.
- No-professionals, must not install and disassemble the lamps.

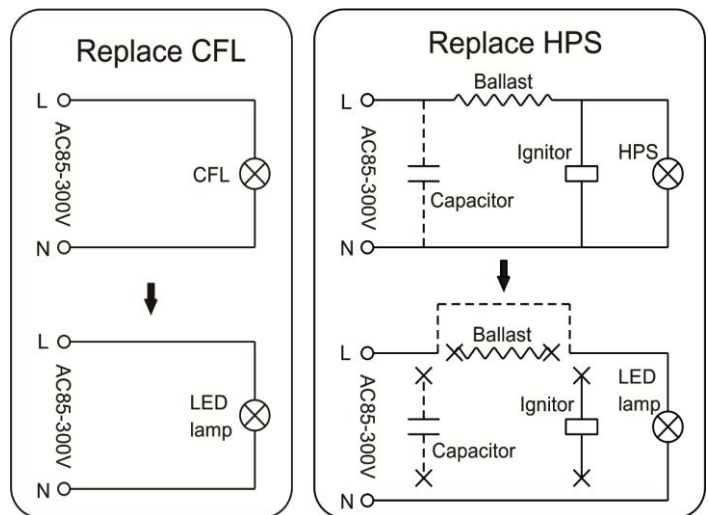

Trouble Shootings

Troubles	Check points
Flickering of the lamps	Turn off the power and turn on again in 3 minutes. If same phenomena occur, then call agencies
Out of working	Please check the connection

NEWLITE SOLUTIONS LTD